

“Managed Co-location and DR Services”

Ensuring Reliability

Creating Lifelines for Connecting Businesses....

HCL

Enterprise Requirement.

BUSINESS IT INFRASTRUCTURE COSTS  **Costly components**

Network Bandwidth –

Robust connectivity to the Internet and/or private IP networks. If demand goes up, additional capacity can be added immediately without increasing and “*Last Mile*” capacity.

Physical Environment –

Business Facilities must be fully equipped with backup power supplies, strict environmental controls, and fire suppression equipment, manageable Cabling and other functional attributes (POWER/ FIRE/ SPACE/ SECURITY/ REDUNDANCY).

Human Resources –

To maintain a 24x7x365 IT infrastructure, manpower cost sometimes exceeds even the component cost.



HCL Infinet's Managed Co-Location Offerings

Creating Lifelines for Connecting Businesses....

HCL



HCL Tier 3 DATA CENTER VIEW

HCL Data Center



Creating Lifelines for Connecting Businesses....

HCL

Salient Features

Physical Infrastructure

Power Availability : n+1 redundancy

Physical Security and Network Security

CCTV Surveillance System

Diverse & Robust Network Connectivity

Managed and Value Added Service Offerings



Physical Layout

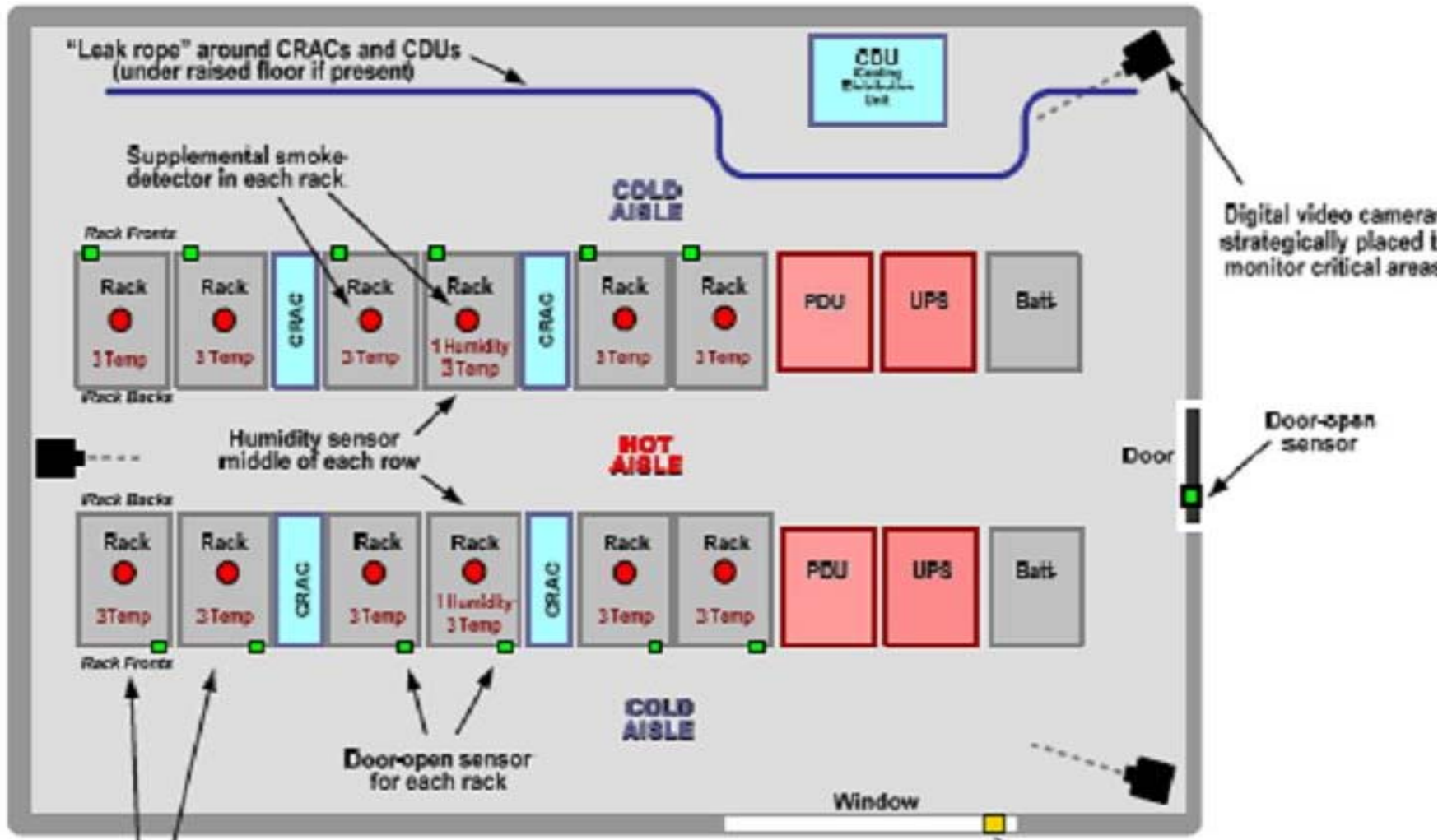

Physical Infrastructure

World Class Tier 3 DC at

- Delhi, Mumbai – 3no's, Chennai, Ahmedabad, Kolkata – 2no's.

Cabling

- Segmented and Structured Cabling.

LAN Segments

- Separate Segments for Internet Gateway for the hosted servers.
- Customer segment tamper-proof
- Each connected to dedicated circuits and subnets

ATM Aggregating Switches

- Carrier-grade Nortel switch

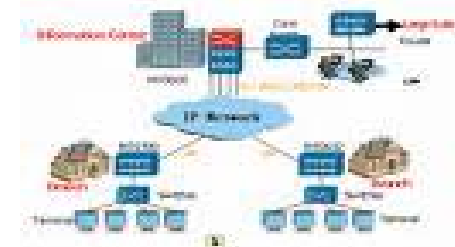
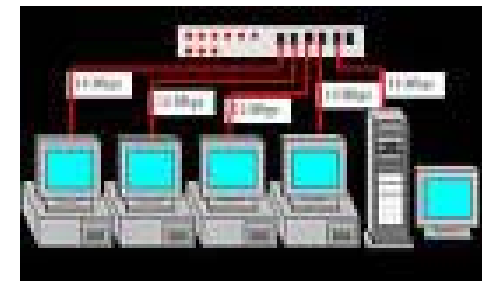

Power

Highest Power Availability , Components in Redundant Mode

- **DG** :24hrs backup diesel generator.
- **UPS** :100% redundant UPS with battery backup, working in failover mode.
- **PDU** :Manages power capacity and functionality for critical network
- **ATS** : Available
- **SMPS** : Available in redundant mode.
Option of AC/DC power supply.

Centralized (Room) Protection Architecture:

Power Architecture to create redundancy ,and to ensure continuity to the infrastructure environment



Security

Physical Security

Highly secure Data Centre following best practices.

Three levels of access authentication

- **First Level:** Manned security provided on 24 X 7.
- **Second Level:** Authentication based on access cards.
- **Third Level:** Biometrics scan, the area with hosted servers are caged for additional security.

Surveillance Cameras with Digital Video Recorder

- Video searches by event, time, date and camera
- Remote access to security footage using a PC



Fire Security

Fire Security

- Fire resistant tiles
- Fire Retardant Doors and Glasses

Second Level Of Risk Mitigation

- VESDA (Very Early Smoke Detection Apparatus)
- FAS (Fire Alarm System)
- GAS Suppression FM200 (For Fire Suppression)

Other Security Measures

- WLD (Water Leak Detection)
- Pest Repellent
- Rodent Triple Agent

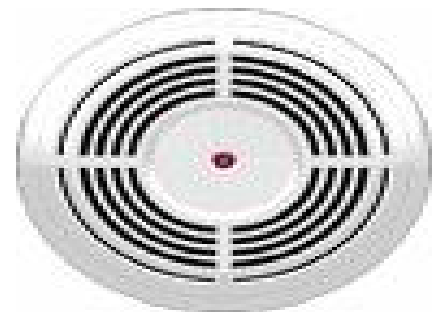

Cooling Infrastructure

High Volume PAC Cooling Systems.

Redundant cooling system

- Hot Aisle and Cool Aisle to be kept separate.
- Elimination of “hot spots”.
- Sizing of Air openings.
- Structured Cabling on racks

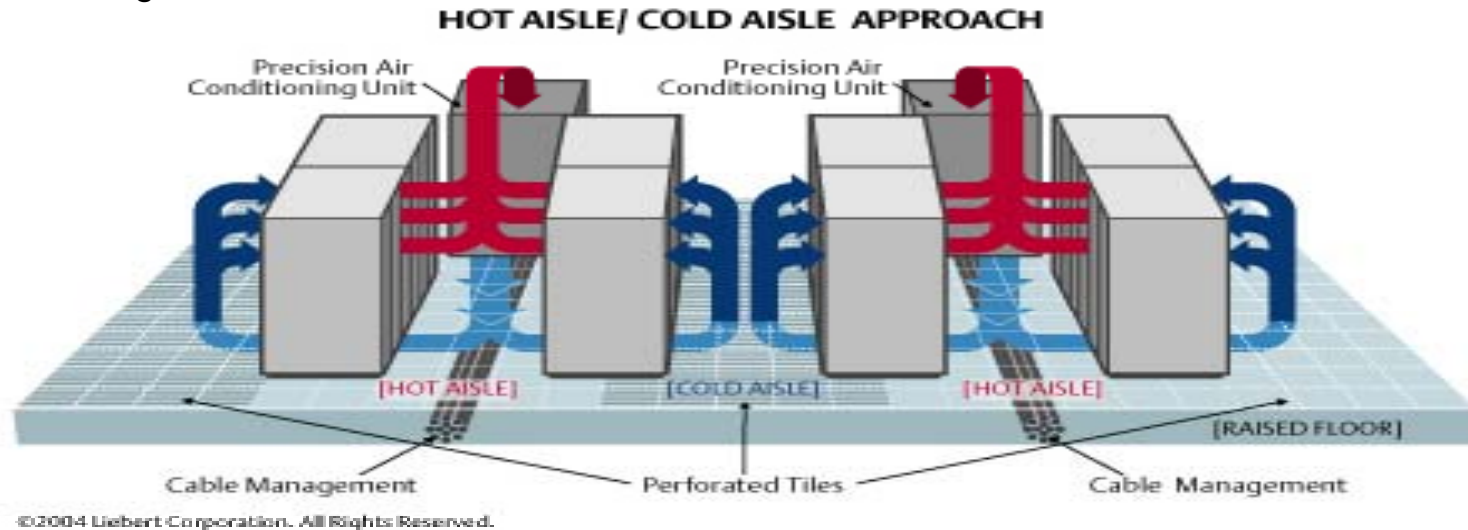

Our Core - Unmatched Service Infrastructure

Backbone built on STM 1 capacities, activated on DS3/E1 basis on reaching 70% Bandwidth utilization

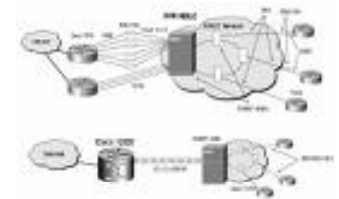

Last mile agnostic, Carrier agnostic, RF Last Mile availability with Redundant Core Backbone Connectivity with >99.9% Uptime which is built on world class technologies from Nortel, Cisco, Juniper for meeting varied service needs

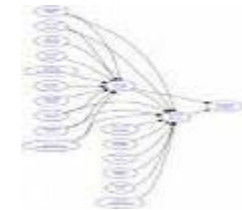

Policy based QoS for supporting Multi Service-Data, Voice and Video

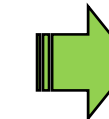

Centralized NOC with fully redundant set-up supporting 24*7 Operations

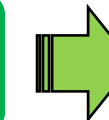

Owned, Operated and Managed by HCL Infinet



HCL INFINET LTD. **HCL**

HCL

Creating Lifelines for Connecting Businesses....

HCL Service Fabric

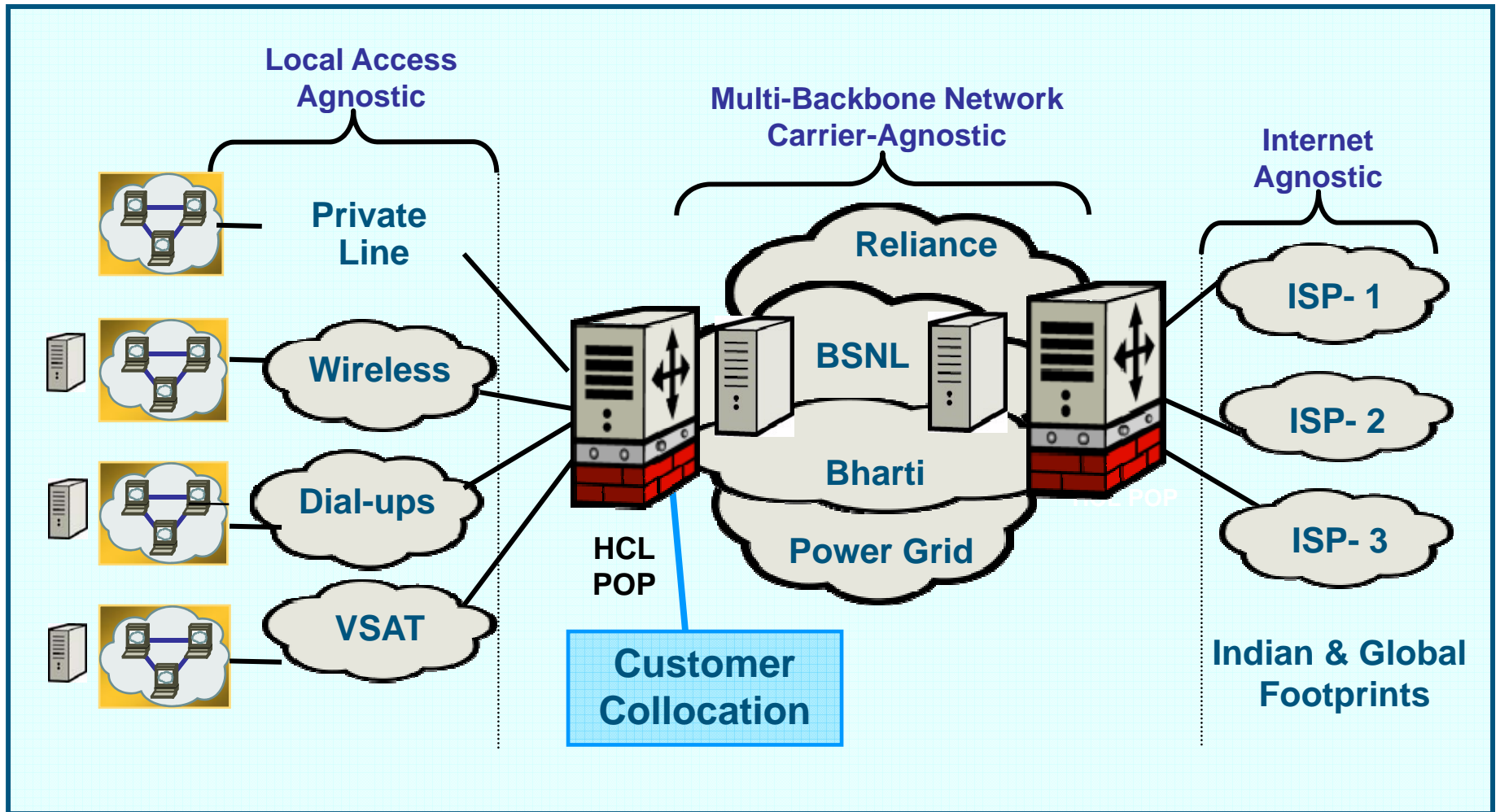

Network Operations Center & Call Center Support

Centralized Help Desk Support: 24X7

Single-Number Support: 1-860-345-3666

Performance & Status Reporting

Tracking Trouble Tickets till Closure

Proactive Reporting of Incidents

CRM Software: HCL View (IMS+ CMS)

Call Handling: ACD and IVR



Value Added Services

FACILITY MANAGEMENT SERVICES

For troubleshooting of tools like SQL, Oracle, JSP, ASP, IIS, Apache, Tomcat, CGI-Perl, PHP etc.

HARDWARE & OS SUPPORT

Overall equipment support with 99% uptime

NETWORK / SERVER MONITORING SERVICES

CA to monitor and report various server / network responses
proactive monitoring of the health of the entire network.

MANAGED FIREWALL –

Complete Security for the servers.

BACK-UP SERVICES-

Application and database backup facility.
Auto scheduling through highly sophisticated tools,
Manual backups



HCL